

Build Kansas Fund | Fiscal Year 2024 Application Package | Memo



To: Senator Ty Masterson, Chair, Build Kansas Advisory Committee
Murl Riedel, Kansas Legislative Research Department
Shauna Wake, Office of the Kansas State Treasurer

From: Vanessa Lamoreaux, Kansas Department of Transportation

RE: Build Kansas Fund Application # 2024-008-NCRPC

Date: February 1, 2024

Attached, please find an application made to the Build Kansas Fund by the City of Concordia.

The application packet includes the following items:

- Coversheet – provides a high-level overview of the application including a unique identification number, page 1 of 10 of the Build Kansas Fund Application Package.
- Build Kansas Fund Application – includes information submitted with the Build Kansas Fund Application, pages 2-8. Page 8 provides the table of funding sources.
- Attachments – Project Narrative, pages 9-10.

Project Overview

The City of Concordia seeks funding from the US Department of Transportation (USDOT), Federal Aviation Administration (FAA) for funding available through the Airport Infrastructure Grant (AIG) to complete construction of a box hangar, installation of associated utilities, pavement marking, and erosion control measures at Blosser Municipal Airport.

AIG is a formula BIL program that has a local match requirement of 10%. The City is requesting \$12,555 from the Build Kansas Fund. This request unlocks \$113,000 in federal funds. AIG can be used to invest in runways, taxiways, safety, terminal, airport-transit connections, and roadway projects.

Applications are due on April 1, 2025. The Build Kansas Fund application was received on December 17, 2023.

Build Kansas Fund Steering Committee Recommendation

The Build Kansas Fund Steering Committee reviewed this application on January 24, 2024, following a successful completeness check. The Steering Committee **RECOMMENDS APPROVAL** of Build Kansas Funding to the Build Kansas Advisory Committee for final advice.

Build Kansas Fund | Fiscal Year 2024 Application Package | Coversheet



Build Kansas Fund Application Number	2024-008-NCRPC
Project Name	City of Concordia Blosser Municipal Airport - Box Hangar
Entity Type	Local Government
Economic Development District (EDD) Planning Commission	NCRPC North Central Regional Planning Commission
Infrastructure Sector(s)	Transportation
BIL Program	Airport Improvement Program (AIP) Grant / Apportionment Data
BIL Program Type	Formula
BIL Application Deadline	4/1/2025
Build Kansas Fund Request	\$12,555
Technical Assistance Received	General No
	BIL Application No
	Build Kansas Fund Application Yes
	Other (Brief Description): Provided support on the budget and application process
Application Notes	Build Kansas Fund contribution of \$12,555 will unlock \$113,000 in federal BIL funding for their FY25 appropriation request.

Steering Committee
Funding Recommendation **January 24, 2024 | Recommend**

Advisory Committee Target Review **DATE**

Advisory Committee
Funding Recommendation **DATE | Approve or Deny**

Completeness Review Data

Date Build Kansas Application Received:	12/17/2024
Date Of Completeness Check:	1/18/2024
Date Forwarded to Steering Committee:	1/19/2024

Title	City of Concordia	12/08/2023
	by Larry Uri in Build Kansas Fund Fiscal Year 2024 Application	id. 44900582
	701 Washington Concordia, Kansas 66901 United States 785-243-2790 citymanager@concordiaks.org	

Original Submission	12/08/2023
----------------------------	------------

Score	n/a
Part 1: Applicant Information	
The name of the entity applying for the Build Kansas Fund:	City of Concordia
Project Name:	Blosser Municipal Airport - Box Hangar
Entity type:	Local Government
Applicant Contact Name:	Amy Lange
Applicant Contact Position/Title:	City Manager
Applicant Contact Telephone Number:	+17852432670
Applicant Contact Email Address:	citymanager@concordiaks.org
Applicant Contact Address:	701 Washington St
Applicant Contact Address Line 2 (optional):	
Applicant Contact City:	Concordia
Applicant Contact State:	Kansas

Applicant Contact Zip 66901
Code:

Is the Project Contact the same as the Applicant Contact? Yes

Part 2: Build Kansas Fund - Eligibility Criteria

Certify that you are pursuing a viable Bipartisan Infrastructure Law (BIL) funding opportunity for which your entity is eligible: Yes

Certify that the Bipartisan Infrastructure Law (BIL) funding opportunity you are pursuing has a non-federal match component: Yes

What is the primary county that the project will occur in? Cloud County

The Build Kansas Fund is intended to support Kansas-based infrastructure projects. Please provide a list of all the zip codes this project will be located in, along with an estimated percent [%] of the project located in that zip code. For example, if seeking funding for road infrastructure, provide a rough percent of the roads expected in each zip code:

[Zip Code Percentage.xlsx](#)

Part 3: Bipartisan Infrastructure Law (BIL) - Grant Application Information
Please Note: This information is related to the federal Bipartisan Infrastructure Law (BIL) funding opportunity to which you will apply. This is NOT information for the Build Kansas Match Fund.

Please enter the Bipartisan Infrastructure Law (BIL) funding opportunity title that the entity is applying for: Airport Infrastructure Grant

What is the funding agency for this Bipartisan Infrastructure Law (BIL) funding opportunity? U.S. Department of Transportation

What is the Assistance Listing Number (ALN) for this Bipartisan Infrastructure Law (BIL) funding opportunity? 20.106

What is the application due date for this Bipartisan Infrastructure Law (BIL) funding opportunity? 4/1/2025

What is the federal fiscal year for this Bipartisan Infrastructure Law (BIL) funding opportunity? 2025

Enter the amount of funding being applied for, from the Bipartisan Infrastructure Law (BIL) funding opportunity: \$113,000

Part 4: Build Kansas Fund - Match Application Information

Enter the non-federal match amount requested from the Build Kansas Fund: \$12,555

Is the project able to move forward with a lesser match amount than requested? No

If you are awarded 0.0
less match than the
amount requested, at
what amount would
your project NOT be
able to move
forward?

Expected breakdown of funding sources to support the project: Enter the funding source and projected amount from each source to support this project:

[Kansas+DOT+table.xlsx](#)

Part 5: Build Kansas Fund - Means Test

Confirm that there are no available funding sources currently planned to go unused by your entity that could be leveraged for this project: Yes

Confirm there are no available American Rescue Plan Act (ARPA) or Coronavirus State & Local Fiscal Recovery Fund monies that could be used for this match: Yes

Confirm that you have explored other readily available funding sources (federal or non-federal) to be used for this match: Yes

Briefly describe your efforts to find other available funding sources for this project:

The City prepares a Capital Improvement Plan (CIP) each year and forecasts several years into the future. All CIP funds currently available have been allocated for other necessary projects. ARPA funds awarded to the City have been spent or allocated on projects currently underway. Local grants do not fund projects of this scope. The City's General Fund is needed and used for operations and maintenance of existing infrastructure, and therefore is not used for improvements. Furthermore, while the City has a healthy Reserve Fund, our auditor has advised us to maintain at least three months' of expenses in this fund in the event of an emergency; drawdown for this project would put us below that amount. The City is also currently acting as the fiscal agent for a large grant for our local Housing Authority, and are awaiting reimbursement from the grant, which has applied pressure to our reserve fund. The City is required to abide by Kansas Cash Basis Law, meaning we must have the cash available in order to spend it.

Part 6: Additional Information

Please upload a copy of the Bipartisan Infrastructure Law (BIL) program application associated with this request OR a 2-page executive summary providing an overview of the project:

[CNK_Hangar_Project_-_Cost_Breakdown_-_12-8-2023_-_FINAL.pdf](#)

Provide any additional information about this project (optional):

Attached is a funding summary for the project. This request for matching funds is to utilize the FY25 BIL funding opportunity to complete the construction of the hangar. This is in direct alignment with the FY24 BIL funding application that has already been submitted through this program.

Part 7: Terms and Conditions

Understanding of Fund Release Requirements:

checked

Understanding of Use of Funds:

checked

Understanding of Reporting Requirements:

checked

Authority to Make Grant Application:

checked

Persons and Titles: The following persons are responsible for making this Build Kansas Fund application.

Amy
Lange

Position/Title:

City Manager

Additional: Amber Farha

Position/Title: Finance Director

Additional: Brad Waller

Position/Title: Airport Planning Consultant

Additional:

Position/Title:

Internal Form

Score n/a

Pre-Award Information:

Eligible for Build Kansas Fund?

ED District: North Central

Project Primary Zip Code: 66901.0

Sector: Transportation

Application ID: 2024-008-NCRPC

Application Overview and Recommendation:

Post-Award Information:

Awarded BIL Grant?

Total Awarded Federal Funding:

Total Build Kansas Match Fund Award:

Build Kansas Match Fund Award Deobligation:

Budget Source	Amount	Project Zip Code	% in Zip Code
BIL Federal Funds (applied for)	\$ 113,000.00	66901	100%
Build Kansas Funds (non-federal match)	\$ 12,555.00		
Additional Project Contribution (if applicable)			
TOTAL PROJECT COST	\$ 125,555.00		

Brief narrative on the scope of work

The proposed project for the City of Concordia at the Blosser Municipal Airport (CNK) will involve the design and construction of a new 80' x 80' box hangar south of the existing terminal ramp and east of the existing taxilanes. The base bid of the design will include the building, one 70' x 20' aviation door on the west side and three pedestrian doors (two on the north side of the building and one on the south), and the concrete for the relocated taxilane centerline and building approach on the west side of the building.

The project will include construction of approximately 943 SY of concrete pavement to connect the new hangar to the existing taxilane. The proposed site layout is attached and included with this document.

The major improvements include the following:

1. Construct new 80' x 80' Box Hangar with single aviation door. Construct approximately 943 S.Y. of new concrete pavement for drive and sidewalks.
2. Grading of surrounding area to tie into existing features.
3. Install storm sewer.
4. Installation of utilities, as required.
5. Pavement marking.
6. Installation of temporary erosion control measures (seed, cover crop, straw wattles, silt fence) to stabilize the on-site soils and prevent soil run-off.

The BIL funding utilized for this project is shown on the FAA's BIL Airport Infrastructure website, located at: <https://www.faa.gov/bil/airport-infrastructure>

Last Saved: 11/27/2023 1:38:23 PM Saved By: BRADLEY, Polite: 11/27/2023 1:45 PM \\Kansas\1308005\130872.00_CNK_Box_Hangar\Eng_Docs\Sheets\CNK_Project_Enblid.dwg

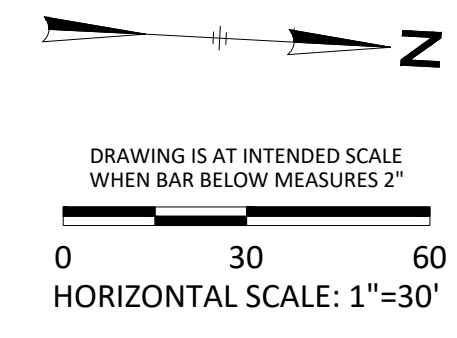
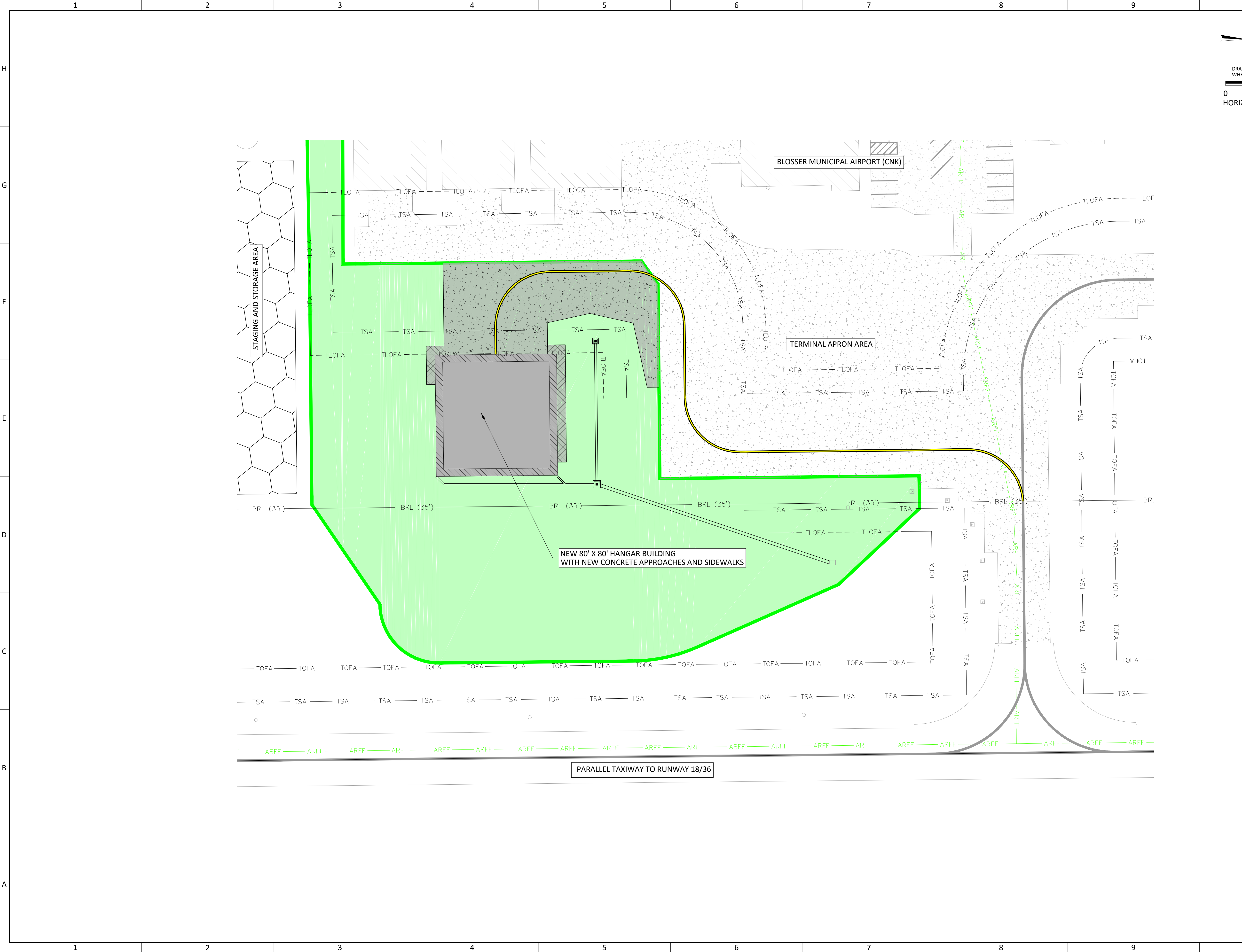

NO.	REVISIONS	DATE



PROJECT PLAN

BLOSSER MUNICIPAL AIRPORT (CNK) - CONCORDIA, KANSAS BOX HANGAR

JGR JonesGillamRenz
730 N. Ninth 1881 Main Street, Suite 301
Salina, KS 67401 Kansas City, MO 64108
785-527-0386 jgr@jgrarchitects.com

benesch
Alfred Benesch & Company
3226 Kregel Avenue
Manhattan, Kansas 66503
785-539-2202

PROJECT	130872.00
DATE	FEBRUARY 06, 2023

SHEET	DRAWING NO.
9/44	C.009